

SINGLE SPEED ELECTRIC CHAIN HOIST

500Kg-5Ton

Shell: Light aluminum alloy shell shall be adopted which is light but hard and fit for the use in the terrible work environment with a high heat dissipation rate and all tightness design.

Inverse phase sequence protecting device: it is the special electrical installation which control the circuit not to work in case of wiring error in the power supply.

Limit switch: The limit switch device is installed where the weight is lifted on and off to make the motor to stop automatically so as to prohibit the chains from exceeding for safety.

24V/36V device: it is used to prohibit the emergencies from occurring in case of the leakage in the switch.

Side magnetic braking device: This device shall realize the instant brake in case of the power dump.

Chain bag: It shall be light, handsome and durable.

Chain: The chain shall adopt the imported FEC80 ultra heat-treatable aluminum alloy chain.



Single Speed

Technical parameters

Model	SL 1T	SL 2T	SL 3T	SL 5T
Capacity(t)	1t	2t	3t	5t
Lifting speed (m/min)	6.6	6.6	5.4	2.7
Motor power (Kw)	1.5	3.0	3.0	3.0
Rotation speed (r/min)	1440			
Insulation grade	F			
Power supply	3 Phase 380V 50Hz			
Control Voltage	24V 36V 48V			
No. Of chain	1	1	1	2
Spec. Of load chain	φ 6.3	φ10.0	φ 11.2	φ 11.2
Net Weight (kg)	47	115	122	151

ELECTRIC TROLLEY

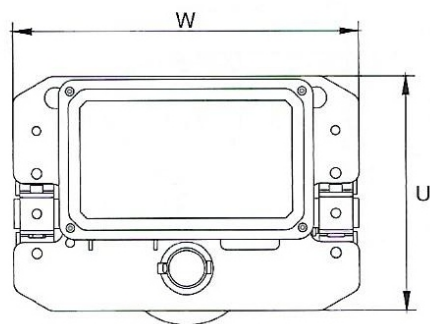
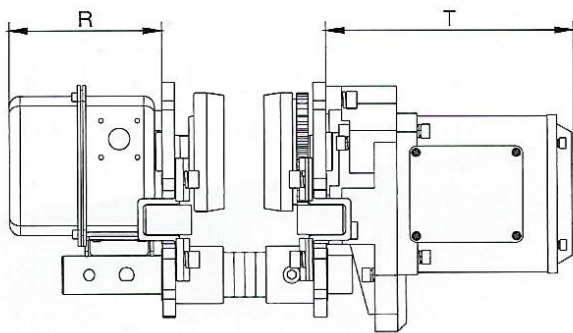

Technical Parameters

Capacity(t)	Unit (mm)				Speed(m/min)	Motor(Kw)	Minimum radius of turn
	W	U	R	T			
0.5	315	212	142	231	21m/min or 11m/min	0.4	0.8
1	315	212	142	231		0.4	0.8
2	325	220	142	231		0.4	0.9
3	340	250	142	231		0.75	1.0
5	400	291	142	231		0.75	1.5
7.5	400	291	142	231		0.75	1.8
10	500	371	142	231		0.75	2.0

SINGLE SPEED ELECTRIC CHAIN HOIST

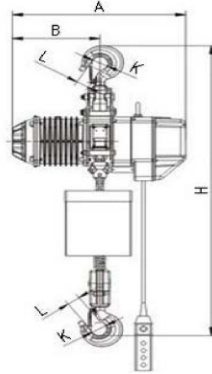

0.3T



5T



10T

		SL05-01T	SL01-01T	SL02-01T	SL03-01T	SL05-02T	SL10-04T
Capacity (t)		1	1	2	3	5	10
Standard lift (m)		6	6	6	6	6	6
Lifting speed (m/min)		7.2	6.6	6.6	5.4	2.7	2.7
Rotation speed (r/min)		1440	1440	1440	1440	1440	1440
Load chain (mm)		Ø7.1	Ø7.1	Ø10	Ø11.2	Ø11.2	Ø11.2
No. of load chain falls		1	1	1	1	2	4
Motor power (kw)		1.5	1.5	3	3	3	3.0 x 2
Power Supply		220-440V, 50/60Hz, 3 Phase					
Dimension (mm)	A	520	520	620	620	620	630
	B	260	260	310	310	310	315
	D	300	300	430	430	430	890
	E	176	176	265	265	325	430
	H	600	600	800	845	1030	1400
	I	Ø40	Ø40	Ø49	Ø59	Ø60	Ø90
	J	Ø31	Ø31	Ø35	Ø42	Ø45	Ø70
	K	Ø40	Ø40	Ø49	Ø49	Ø60	Ø90
	L	31	31	35	42	45	65
	M	24	24	30	35	43	107
N	24	24	30	35	43	50	

Remarks: 1. Fitting with single-speed electric trolley is available. 2. Dual speed type is available for 0.5T ~ 10T models.