

# MOVEABLE STEEL GANTRY CRANE

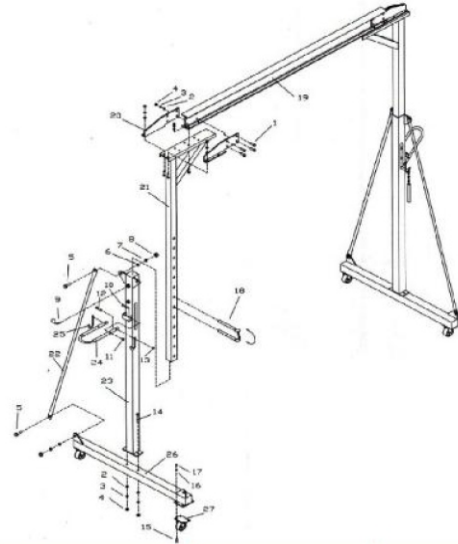

## Feature

- » Robust light weight steel construction
- » Can go where forklift or stacker can not.
- » Heavy duty supported leg design.
- » Balanced design allows for easy maneuvering, even under load.
- » Simple bolted construction.
- » Easy for assembly, disassembly and maintenance.
- » 4 casters to keep good moveability and maneuverability.
- » Patented product, all right reserved.
- » Comply with standards EN ISO12100-1:2003 & EN ISO12100-2:2003.
- » Comply with ANSI/ASME B30.17 standard.



Model	Capacity		Operating height		Width between uprights		Casters		N.W.		20'ft Container
	(kg)	(lbs)	(mm)	(feet)	(mm)	(feet)	(inch)	(q'ty)	(kg)	(lbs)	(pcs)
SB0901	500	1100	2400~3600	7 7/8~11 4/5	2400	7 5/6	3.5	4	100	220	165
SB0902	1000	2200	2400~3600	7 7/8~11 4/5	2400	7 5/6	5	4	120	264	121
SB0903	1500	3300	2400~3600	7 7/8~11 4/5	2400	7 5/6	5	4	150	330	110
SB0904	2000	4400	2400~3600	7 7/8~11 4/5	2400	7 5/6	5	4	160	353	90

\* DO NOT move while loaded. \*

